

Points missed: _____ Student's Name: _____

Total score: _____/100 points

East Tennessee State University
Department of Computer and Information Sciences
CSCI 2150 (Tarnoff) – Computer Organization
TEST 2 for Fall Semester, 2008

Read this before starting!

- The total possible score for this test is 100 points.
- This test is *closed book and closed notes*.
- *Please turn off all cell phones & pagers during the test.*
- **All** answers **must** be placed in space provided. Failure to do so may result in loss of points.
- **1 point** will be deducted per answer for missing or incorrect units when required. **No** assumptions will be made for hexadecimal versus decimal, so you should always include the base in your answer.
- If you perform work on the back of a page in this test, indicate that you have done so in case the need arises for partial credit to be determined.
- **Calculators are not allowed.** Use the tables below for any conversions you may need. Leaving numeric equations is fine too.

Binary	Hex
0000	0
0001	1
0010	2
0011	3
0100	4
0101	5
0110	6
0111	7

Binary	Hex
1000	8
1001	9
1010	A
1011	B
1100	C
1101	D
1110	E
1111	F

Power of 2	Equals
2^3	8
2^4	16
2^5	32
2^6	64
2^7	128
2^8	256
2^9	512
2^{10}	1K
2^{20}	1M
2^{30}	1G

“Fine print”

Academic Misconduct:

Section 5.7 "Academic Misconduct" of the East Tennessee State University Faculty Handbook, June 1, 2001:

"Academic misconduct will be subject to disciplinary action. Any act of dishonesty in academic work constitutes academic misconduct. This includes plagiarism, the changing of falsifying of any academic documents or materials, cheating, and the giving or receiving of unauthorized aid in tests, examinations, or other assigned school work. Penalties for academic misconduct will vary with the seriousness of the offense and may include, but are not limited to: a grade of 'F' on the work in question, a grade of 'F' of the course, reprimand, probation, suspension, and expulsion. For a second academic offense the penalty is permanent expulsion."

Short answers – 2 points each unless otherwise noted

For the following **three** circuits, identify the value of the output Q from the following choices. Consider the D-latch a **rising edge triggered latch**. (1 point each)

- a.) 1 b.) 0 c.) Q₀ (stored value of Q) d.) undefined/illegal e.) can't tell

1. Answer: _____ 2. Answer: _____ 3. Answer: _____

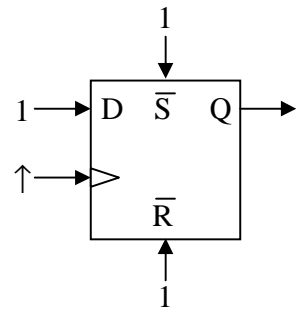
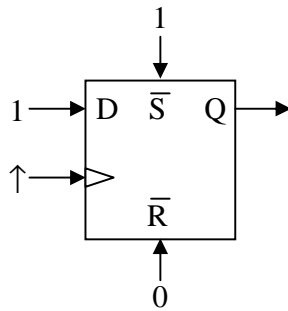
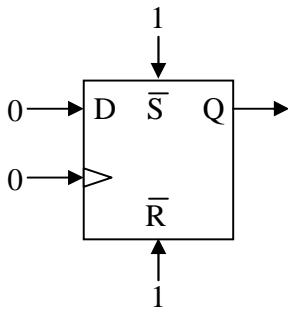

4. A transparent active low D-latch copies data from the D input to the Q output:
 a.) the instant the clock changes from a 1 to a 0 c.) as long as the clock equals 0
 b.) the instant the clock changes from a 0 to a 1 d.) as long as the clock equals 1

5. If you were to make an **un-simplified** Product-of-Sums expression directly from the truth table shown to the right, how many "sums" would it have? For example, the POS expression $(\bar{A} + B + C) \cdot (A + \bar{B} + \bar{C}) \cdot (A + B + C)$ contains three sums.

- a.) 1 b.) 2 c.) 3 d.) 4 e.) 5 f.) 6

A	B	C	X
0	0	0	1
0	0	1	1
0	1	0	0
0	1	1	1
1	0	0	0
1	0	1	1
1	1	0	1
1	1	1	1

6. True or false: The boolean expression $X = \bar{A} \cdot B \cdot C + \bar{A} \cdot B \cdot \bar{C} + A \cdot B$ is in proper Sum-of-Products format.

7. In the space below, write the product that represents the boolean expression for X in the truth table to the right.

A	B	C	X
0	0	0	0
0	0	1	1
0	1	0	0
0	1	1	0
1	0	0	0
1	0	1	0
1	1	0	0
1	1	1	0

8. How many cells would a four-input (four-variable) Karnaugh Map have?
 a.) 2 b.) 4 c.) 6 d.) 8 e.) 12 f.) 16 g.) 32

9. In a four-variable Karnaugh map, how many input variables (A, B, C, and/or D) does a single product have if its corresponding rectangle of 1's contains 8 cells?
 a.) 1 b.) 2 c.) 3 d.) Cannot be determined

10. True or False: If done properly, there is exactly one possible arrangement for all of the rectangles of ones in a Karnaugh map.

11. Make the connections to the latch in the figure to the right that makes a divide-by-two circuit, i.e., divides the frequency F in half at the output Q.

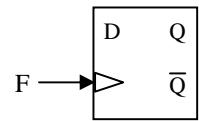

12. True or False: The two circuits below are equal.

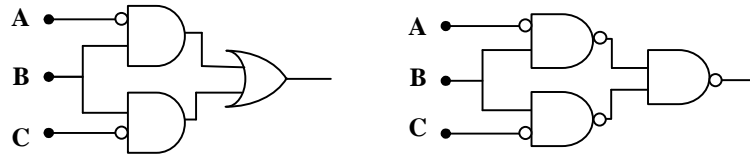

13. For the circuit to the right, what value does Q have? (2 points)

- a.) 0
- b.) 1
- c.) Must know previous value for Q to answer.
- d.) Illegal state. Should never have these inputs.

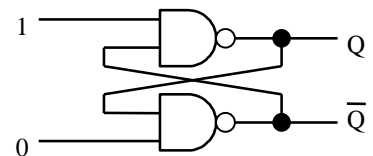

The next six problems use the state machine circuit to the right. Assume that the states are numbered so that bit S_3 is the most significant bit and bit S_0 is the least significant bit.

14. What is the maximum number of states that this system can handle?

15. What is the current state of this system? Keep your answer in binary.

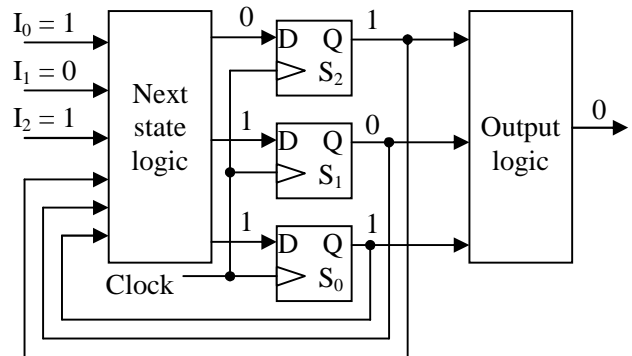

16. If the clock were to pulse right now, what would the next state be? Keep your answer in binary.

17. The truth table to the right represents the output logic truth table for the above state machine. Circle the row that identifies the current output condition of the system, i.e., which row is represented by the **current state** of the logic in the diagram above without having any clock pulses occur?

S_2	S_1	S_0	X
0	0	0	1
0	0	1	0
0	1	0	1
0	1	1	0
1	0	0	1
1	0	1	0
1	1	0	1
1	1	1	1

18. If the clock were to pulse right now, what would the new output be? Use the truth table from the previous problem to answer the question.

- a.) 0
- b.) 1
- c.) Not enough information given

19. How many rows would the next state logic truth table have for this circuit?

- a.) $2^2 = 4$
- b.) $2^3 = 8$
- c.) $2^4 = 16$
- d.) $2^5 = 32$
- e.) $2^6 = 64$
- f.) $2^7 = 128$

20. True or False: Re-numbering the states of a state machine has no effect on the "next state" logic for the digital hardware implementation.

21. How many latches will a state machine with 64 states require?

- a.) 3 b.) 4 c.) 5 d.) 6 e.) 7 f.) 8 g.) 9

22. For the multiplexer/selecter shown to the right, what is the output Y equal to?

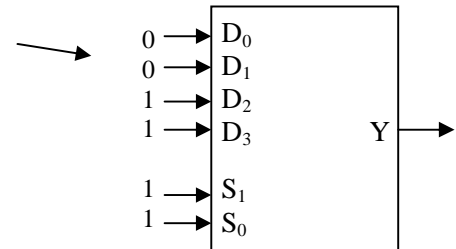

23. For the **active-low** output decoder shown to the right, fill in the values for all of the outputs D_0 through D_7 . Assume S_2 is most significant bit of the inputs.

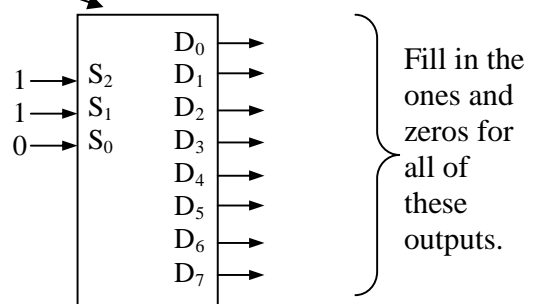

24. Identify the 2 errors in the state diagram to the right. The circuit is to have a single binary input K. Do not bother to correct the errors. (2 points for each error identified correctly)

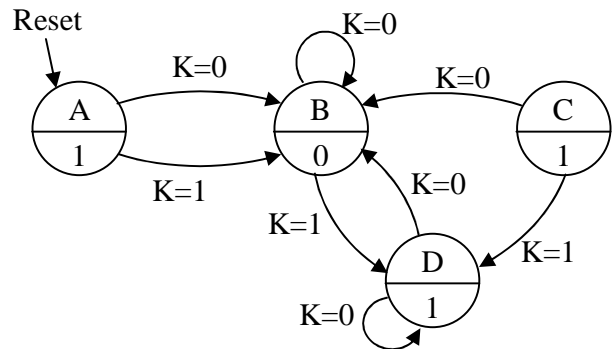

25. For the Karnaugh map to the right, identify three **mistakes** with how the rectangles have been made. Note that not all of the problems may be with a specific rectangle, but if there is a problem with a rectangle, be sure to identify it using the names given. (2 points each)

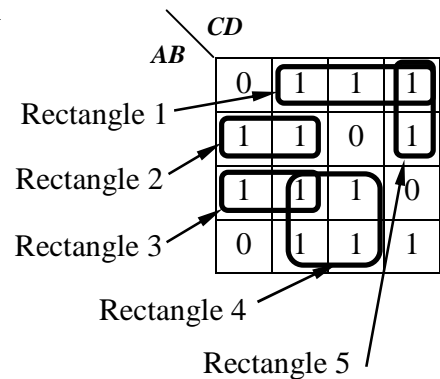

Mistake 1:

Mistake 2:

Mistake 3:

Medium answers – 4 points each

26. Complete the truth table to the right with the values for the sum-of-products expression $A + B \cdot \bar{C}$.

A	B	C	X
0	0	0	
0	0	1	
0	1	0	
0	1	1	
1	0	0	
1	0	1	
1	1	0	
1	1	1	

27. In the Karnaugh map to the right, draw the best pattern of rectangles you can. **Do not derive the SOP expression.**

		CD			
		00	01	11	10
AB	00	0	0	0	1
	01	X	X	X	X
	11	0	0	1	1
	10	1	1	1	1

28. In the space to the right, draw the decoding logic circuit with an active-low output that identifies when $A = 0$, $B = 1$, $C = 1$, $D = 1$, and $E = 0$.

29. Create a Karnaugh map from the truth table below. **Do not worry about making the rectangles.**

A	B	C	X
0	0	0	0
0	0	1	1
0	1	0	0
0	1	1	1
1	0	0	0
1	0	1	0
1	1	0	1
1	1	1	1

30. Show the D latch output waveform Q based on the inputs D , \bar{S} , \bar{R} , and clock indicated in the graph to the right. Assume the latch captures on the rising edge. (The figure below is just for a reference.)

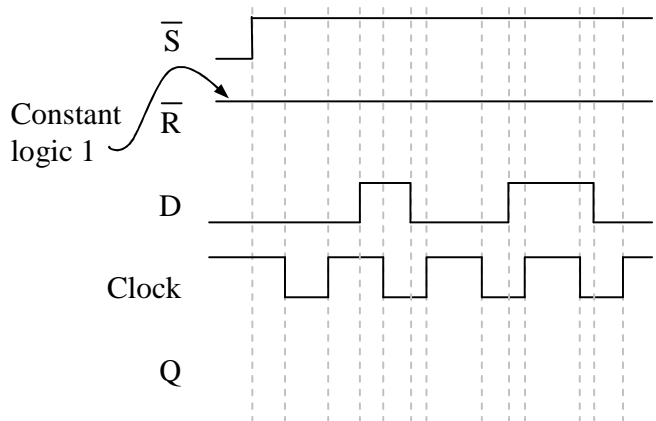
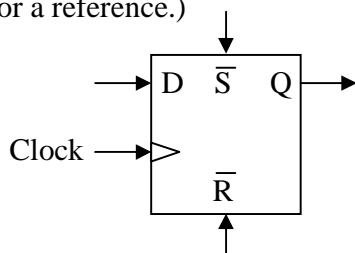

Longer answers – Points vary per problem

31. Make the state diagram that will output a '1' when the sequence '011' is detected in a serial stream of bits. For example, if the following binary stream is received:

0 1 0 1 1 1 0 1 1 1 0 0 1 1 0 0 0 1 1 1 1 0 0 1 0 0 1 1

then 1's will be output at these points. At all other times, the system will output zeros. **Label the input D.** (7 points)

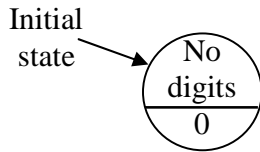

32. Create the next state truth table and the output truth table for the state diagram to the right. The states have already been numbered. Use the variable names S_1 and S_0 to represent the most significant and least significant bits respectively of the binary number identifying the state. Label the output 'X'. (7 points)

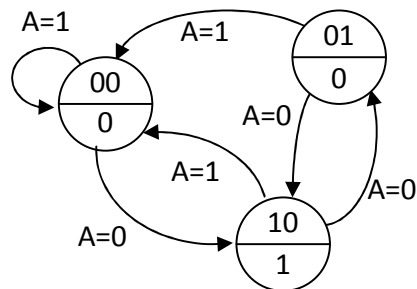

33. Derive the minimum SOP expression from the Karnaugh map below. (6 points)

	CD			
	00	01	11	10
AB				
00	1	0	1	1
01	1	0	1	1
11	1	1	1	1
10	0	0	1	0

34. The three Boolean expressions below represent the *next state bits* (S_0' and S_1') and the *output bit* X based on the *current state* (S_0 and S_1) and the *input* A . Draw the logic circuit for the state machine including the latches and output circuitry. **Be sure to label the latch inputs and other signals.** (7 points)

$$S_0' = \overline{S_1}$$

$$S_1' = A \cdot S_0$$

$$X = S_0$$