

# Linear Algebra

## Chapter 4: Determinants

### Section 4.1. Areas, Volumes, and Cross Products—Proofs of Theorems

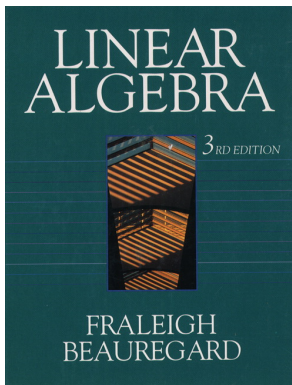

# Table of contents

- 1 Page 248 Number 20
- 2 Page 249 Number 26
- 3 Page 248 Number 16
- 4 Theorem 4.1.A. Area of a Parallelogram
- 5 Theorem 4.1.B. Volume of a Box
- 6 Page 249 Number 38
- 7 Page 249 Number 50
- 8 Theorem 4.1. Properties of Cross Product
- 9 Page 249 Number 56

## Page 248 Number 20

**Page 248 Number 20.** Find the area of the parallelogram with vertex at the origin and with vectors  $-\hat{i} + 4\hat{j}$  and  $2\hat{i} + 3\hat{j}$  (in standard position) as edges.

**Solution.** We have  $-\hat{i} + 4\hat{j} = [-1, 4] = [a_1, a_2]$  and  $2\hat{i} + 3\hat{j} = [2, 3] = [b_1, b_2]$  so the area of the parallelogram is  $|\det(A)|$  where  $A = \begin{bmatrix} a_1 & a_2 \\ b_1 & b_2 \end{bmatrix} = \begin{bmatrix} -1 & 4 \\ 2 & 3 \end{bmatrix}$ .

## Page 248 Number 20

**Page 248 Number 20.** Find the area of the parallelogram with vertex at the origin and with vectors  $-\hat{i} + 4\hat{j}$  and  $2\hat{i} + 3\hat{j}$  (in standard position) as edges.

**Solution.** We have  $-\hat{i} + 4\hat{j} = [-1, 4] = [a_1, a_2]$  and  $2\hat{i} + 3\hat{j} = [2, 3] = [b_1, b_2]$  so the area of the parallelogram is  $|\det(A)|$  where  $A = \begin{bmatrix} a_1 & a_2 \\ b_1 & b_2 \end{bmatrix} = \begin{bmatrix} -1 & 4 \\ 2 & 3 \end{bmatrix}$ . Hence the area is

$$|\det(A)| = \left| \begin{vmatrix} -1 & 4 \\ 2 & 3 \end{vmatrix} \right| = |(-1)(3) - (4)(2)| = \boxed{11}.$$

□

## Page 248 Number 20

**Page 248 Number 20.** Find the area of the parallelogram with vertex at the origin and with vectors  $-\hat{i} + 4\hat{j}$  and  $2\hat{i} + 3\hat{j}$  (in standard position) as edges.

**Solution.** We have  $-\hat{i} + 4\hat{j} = [-1, 4] = [a_1, a_2]$  and  $2\hat{i} + 3\hat{j} = [2, 3] = [b_1, b_2]$  so the area of the parallelogram is  $|\det(A)|$  where  $A = \begin{bmatrix} a_1 & a_2 \\ b_1 & b_2 \end{bmatrix} = \begin{bmatrix} -1 & 4 \\ 2 & 3 \end{bmatrix}$ . Hence the area is

$$|\det(A)| = \left| \begin{vmatrix} -1 & 4 \\ 2 & 3 \end{vmatrix} \right| = |(-1)(3) - (4)(2)| = \boxed{11}.$$

□

# Page 249 Number 26

**Page 249 Number 26.** Find the area of the triangle with vertices  $(3, -4)$ ,  $(1, 1)$ , and  $(5, 7)$ .

**Solution.** First notice that:

## Page 249 Number 26

**Page 249 Number 26.** Find the area of the triangle with vertices  $(3, -4)$ ,  $(1, 1)$ , and  $(5, 7)$ .

**Solution.** First notice that:

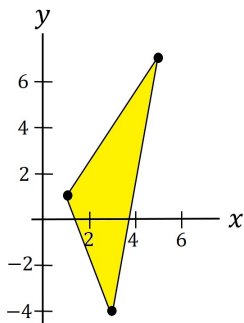

## Page 249 Number 26

**Page 249 Number 26.** Find the area of the triangle with vertices  $(3, -4)$ ,  $(1, 1)$ , and  $(5, 7)$ .

**Solution.** First notice that:

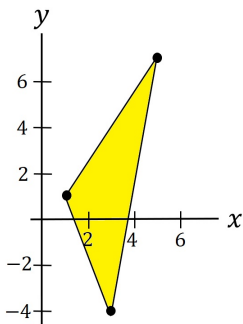

So we introduce vector  $\vec{a}$  from  $(1, 1)$  to  $(3, -4)$  and vector  $\vec{b}$  from  $(1, 1)$  to  $(5, 7)$ , so that  $\vec{a} = [a_1, a_2] = [(3) - (1), (-4) - (1)] = [2, -5]$  and  $\vec{b} = [b_1, b_2] = [(5) - (1), (7) - (1)] = [4, 6]$ .



# Page 249 Number 26

**Page 249 Number 26.** Find the area of the triangle with vertices  $(3, -4)$ ,  $(1, 1)$ , and  $(5, 7)$ .

**Solution.** First notice that:

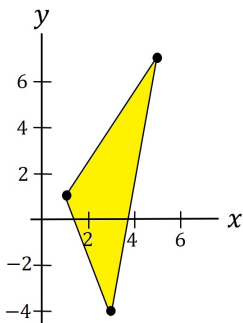

So we introduce vector  $\vec{a}$  from  $(1, 1)$  to  $(3, -4)$  and vector  $\vec{b}$  from  $(1, 1)$  to  $(5, 7)$ , so that  $\vec{a} = [a_1, a_2] = [(3) - (1), (-4) - (1)] = [2, -5]$  and  $\vec{b} = [b_1, b_2] = [(5) - (1), (7) - (1)] = [4, 6]$ .

## Page 249 Number 26 (continued)

**Page 249 Number 26.** Find the area of the triangle with vertices  $(3, -4)$ ,  $(1, 1)$ , and  $(5, 7)$ .

**Solution (continued).** We can then find the area of the parallelogram determined by  $\vec{a}$  and  $\vec{b}$  using the determinant; but this must be halved to find the area of the desired triangle:

# Page 249 Number 26 (continued)

**Page 249 Number 26.** Find the area of the triangle with vertices  $(3, -4)$ ,  $(1, 1)$ , and  $(5, 7)$ .

**Solution (continued).** We can then find the area of the parallelogram determined by  $\vec{a}$  and  $\vec{b}$  using the determinant; but this must be halved to find the area of the desired triangle:

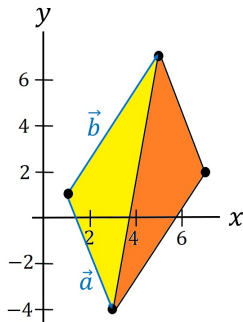

# Page 249 Number 26 (continued)

**Page 249 Number 26.** Find the area of the triangle with vertices  $(3, -4)$ ,  $(1, 1)$ , and  $(5, 7)$ .

**Solution (continued).** We can then find the area of the parallelogram determined by  $\vec{a}$  and  $\vec{b}$  using the determinant; but this must be halved to find the area of the desired triangle:

So the area of the triangle is  $\frac{1}{2}|\det(A)|$  where  $A = \begin{bmatrix} a_1 & a_2 \\ b_1 & b_2 \end{bmatrix} = \begin{bmatrix} 2 & -5 \\ 4 & 6 \end{bmatrix}$ . Then the area is

$$\frac{1}{2}|\det(A)| = \frac{1}{2} \left| \begin{vmatrix} 2 & -5 \\ 4 & 6 \end{vmatrix} \right| = \frac{1}{2} |(2)(6) - (-5)(4)| = \frac{1}{2} |32| = \boxed{16}$$

□

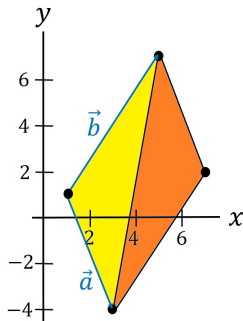

# Page 249 Number 26 (continued)

**Page 249 Number 26.** Find the area of the triangle with vertices  $(3, -4)$ ,  $(1, 1)$ , and  $(5, 7)$ .

**Solution (continued).** We can then find the area of the parallelogram determined by  $\vec{a}$  and  $\vec{b}$  using the determinant; but this must be halved to find the area of the desired triangle:

So the area of the triangle is  $\frac{1}{2}|\det(A)|$  where  $A = \begin{bmatrix} a_1 & a_2 \\ b_1 & b_2 \end{bmatrix} = \begin{bmatrix} 2 & -5 \\ 4 & 6 \end{bmatrix}$ . Then the area is

$$\frac{1}{2}|\det(A)| = \frac{1}{2} \left| \begin{vmatrix} 2 & -5 \\ 4 & 6 \end{vmatrix} \right| = \frac{1}{2} |(2)(6) - (-5)(4)| = \frac{1}{2} |32| = \boxed{16}$$

□

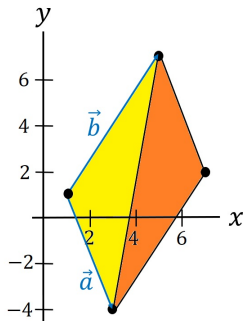

## Page 248 Number 16

**Page 248 Number 16.** Let  $\vec{a} = \hat{i} - \hat{j} + \hat{k}$  and  $\vec{b} = 3\hat{i} - 2\hat{j} + 7\hat{k}$ . Find  $\vec{a} \times \vec{b}$ .

**Solution.** We have  $\vec{a} = [a_1, a_2, a_3] = [1, -1, 1]$  and  $\vec{b} = [b_1, b_2, b_3] = [3, -2, 7]$ .

## Page 248 Number 16

**Page 248 Number 16.** Let  $\vec{a} = \hat{i} - \hat{j} + \hat{k}$  and  $\vec{b} = 3\hat{i} - 2\hat{j} + 7\hat{k}$ . Find  $\vec{a} \times \vec{b}$ .

**Solution.** We have  $\vec{a} = [a_1, a_2, a_3] = [1, -1, 1]$  and  $\vec{b} = [b_1, b_2, b_3] = [3, -2, 7]$ . Then by definition,

$$\begin{aligned} \vec{a} \times \vec{b} &= \begin{vmatrix} a_2 & a_3 \\ b_2 & b_3 \end{vmatrix} \hat{i} - \begin{vmatrix} a_1 & a_3 \\ b_1 & b_3 \end{vmatrix} \hat{j} + \begin{vmatrix} a_1 & a_2 \\ b_1 & b_2 \end{vmatrix} \hat{k} \\ &= \begin{vmatrix} -1 & 1 \\ -2 & 7 \end{vmatrix} \hat{i} - \begin{vmatrix} 1 & 1 \\ 3 & 7 \end{vmatrix} \hat{j} + \begin{vmatrix} 1 & -1 \\ 3 & -2 \end{vmatrix} \hat{k} \end{aligned}$$

## Page 248 Number 16

**Page 248 Number 16.** Let  $\vec{a} = \hat{i} - \hat{j} + \hat{k}$  and  $\vec{b} = 3\hat{i} - 2\hat{j} + 7\hat{k}$ . Find  $\vec{a} \times \vec{b}$ .

**Solution.** We have  $\vec{a} = [a_1, a_2, a_3] = [1, -1, 1]$  and  $\vec{b} = [b_1, b_2, b_3] = [3, -2, 7]$ . Then by definition,

$$\begin{aligned}
 \vec{a} \times \vec{b} &= \begin{vmatrix} a_2 & a_3 \\ b_2 & b_3 \end{vmatrix} \hat{i} - \begin{vmatrix} a_1 & a_3 \\ b_1 & b_3 \end{vmatrix} \hat{j} + \begin{vmatrix} a_1 & a_2 \\ b_1 & b_2 \end{vmatrix} \hat{k} \\
 &= \begin{vmatrix} -1 & 1 \\ -2 & 7 \end{vmatrix} \hat{i} - \begin{vmatrix} 1 & 1 \\ 3 & 7 \end{vmatrix} \hat{j} + \begin{vmatrix} 1 & -1 \\ 3 & -2 \end{vmatrix} \hat{k} \\
 &= ((-1)(7) - (1)(-2))\hat{i} - ((1)(7) - (1)(3))\hat{j} \\
 &\quad + ((1)(-2) - (-1)(3))\hat{k} \\
 &= \boxed{-5\hat{i} - 4\hat{j} + \hat{k} = [-5, -4, 1]}.
 \end{aligned}$$

□



## Page 248 Number 16

**Page 248 Number 16.** Let  $\vec{a} = \hat{i} - \hat{j} + \hat{k}$  and  $\vec{b} = 3\hat{i} - 2\hat{j} + 7\hat{k}$ . Find  $\vec{a} \times \vec{b}$ .

**Solution.** We have  $\vec{a} = [a_1, a_2, a_3] = [1, -1, 1]$  and  $\vec{b} = [b_1, b_2, b_3] = [3, -2, 7]$ . Then by definition,

$$\begin{aligned} \vec{a} \times \vec{b} &= \begin{vmatrix} a_2 & a_3 \\ b_2 & b_3 \end{vmatrix} \hat{i} - \begin{vmatrix} a_1 & a_3 \\ b_1 & b_3 \end{vmatrix} \hat{j} + \begin{vmatrix} a_1 & a_2 \\ b_1 & b_2 \end{vmatrix} \hat{k} \\ &= \begin{vmatrix} -1 & 1 \\ -2 & 7 \end{vmatrix} \hat{i} - \begin{vmatrix} 1 & 1 \\ 3 & 7 \end{vmatrix} \hat{j} + \begin{vmatrix} 1 & -1 \\ 3 & -2 \end{vmatrix} \hat{k} \\ &= ((-1)(7) - (1)(-2))\hat{i} - ((1)(7) - (1)(3))\hat{j} \\ &\quad + ((1)(-2) - (-1)(3))\hat{k} \\ &= \boxed{-5\hat{i} - 4\hat{j} + \hat{k} = [-5, -4, 1].} \end{aligned}$$

□

## Theorem 4.1.A

**Theorem 4.1.A.** The area of the parallelogram determined by  $\vec{b}$  and  $\vec{c}$  in  $\mathbb{R}^3$  is  $\|\vec{b} \times \vec{c}\|$ .

**Proof.** We know from the first note of this section that the area squared is  $A^2 = \|\vec{c}\|^2\|\vec{b}\|^2 - (\vec{c} \cdot \vec{b})^2$ . In terms of components we have

$$A^2 = (c_1^2 + c_2^2 + c_3^2)(b_1^2 + b_2^2 + b_3^2) - (c_1b_1 + c_2b_2 + c_3b_3)^2.$$

## Theorem 4.1.A

**Theorem 4.1.A.** The area of the parallelogram determined by  $\vec{b}$  and  $\vec{c}$  in  $\mathbb{R}^3$  is  $\|\vec{b} \times \vec{c}\|$ .

**Proof.** We know from the first note of this section that the area squared is  $A^2 = \|\vec{c}\|^2\|\vec{b}\|^2 - (\vec{c} \cdot \vec{b})^2$ . In terms of components we have

$$A^2 = (c_1^2 + c_2^2 + c_3^2)(b_1^2 + b_2^2 + b_3^2) - (c_1b_1 + c_2b_2 + c_3b_3)^2.$$

Multiplying out we have

$$\begin{aligned} A^2 &= c_1^2b_1^2 + c_1^2b_2^2 + c_1^2b_3^2 + c_2^2b_1^2 + c_2^2b_2^2 + c_2^2b_3^2 + c_3^2b_1^2 + c_3^2b_2^2 + c_3^2b_3^2 \\ &\quad - (c_1^2b_1^2 + c_2^2b_2^2 + c_3^2b_3^2 + 2c_1b_1c_2b_2 + 2c_1b_1c_3b_3 + 2c_2b_2c_3b_3) \\ &= (c_3^2b_2^2 - 2c_2b_2c_3b_3 + c_2^2b_3^2) + (c_3^2b_1^2 - 2c_1b_1c_3b_3 + c_1^2b_3^2) \\ &\quad + (c_2^2b_1^2 - 2c_1b_1c_2b_2 + c_1^2b_2^2) \\ &= (b_2c_3 - b_3c_2)^2 + (b_1c_3 - b_3c_1)^2 + (b_1c_2 - b_2c_1)^2 \end{aligned}$$

...

## Theorem 4.1.A

**Theorem 4.1.A.** The area of the parallelogram determined by  $\vec{b}$  and  $\vec{c}$  in  $\mathbb{R}^3$  is  $\|\vec{b} \times \vec{c}\|$ .

**Proof.** We know from the first note of this section that the area squared is  $A^2 = \|\vec{c}\|^2\|\vec{b}\|^2 - (\vec{c} \cdot \vec{b})^2$ . In terms of components we have

$$A^2 = (c_1^2 + c_2^2 + c_3^2)(b_1^2 + b_2^2 + b_3^2) - (c_1b_1 + c_2b_2 + c_3b_3)^2.$$

Multiplying out we have

$$\begin{aligned} A^2 &= c_1^2b_1^2 + c_1^2b_2^2 + c_1^2b_3^2 + c_2^2b_1^2 + c_2^2b_2^2 + c_2^2b_3^2 + c_3^2b_1^2 + c_3^2b_2^2 + c_3^2b_3^2 \\ &\quad - (c_1^2b_1^2 + c_2^2b_2^2 + c_3^2b_3^2 + 2c_1b_1c_2b_2 + 2c_1b_1c_3b_3 + 2c_2b_2c_3b_3) \\ &= (c_3^2b_2^2 - 2c_2b_2c_3b_3 + c_2^2b_3^2) + (c_3^2b_1^2 - 2c_1b_1c_3b_3 + c_1^2b_3^2) \\ &\quad + (c_2^2b_1^2 - 2c_1b_1c_2b_2 + c_1^2b_2^2) \\ &= (b_2c_3 - b_3c_2)^2 + (b_1c_3 - b_3c_1)^2 + (b_1c_2 - b_2c_1)^2 \end{aligned}$$

...

## Theorem 4.1.A (continued)

**Theorem 4.1.A.** The area of the parallelogram determined by  $\vec{b}$  and  $\vec{c}$  in  $\mathbb{R}^3$  is  $\|\vec{b} \times \vec{c}\|$ .

**Proof (continued).** ...

$$\begin{aligned} A^2 &= (b_2c_3 - b_3c_2)^2 + (b_1c_3 - b_3c_1)^2 + (b_1c_2 - b_2c_1)^2 \\ &= \begin{vmatrix} b_2 & b_3 \\ c_2 & c_3 \end{vmatrix}^2 + \begin{vmatrix} b_1 & b_3 \\ c_1 & c_3 \end{vmatrix}^2 + \begin{vmatrix} b_1 & b_2 \\ c_1 & c_2 \end{vmatrix}^2 \\ &= \left\| \begin{vmatrix} b_2 & b_3 \\ c_2 & c_3 \end{vmatrix} \hat{i} - \begin{vmatrix} b_1 & b_3 \\ c_1 & c_3 \end{vmatrix} \hat{j} + \begin{vmatrix} b_1 & b_2 \\ c_1 & c_2 \end{vmatrix} \hat{k} \right\| = \|\vec{b} \times \vec{c}\|^2. \end{aligned}$$

Taking square roots we see that the claim is verified. □

## Theorem 4.1.A (continued)

**Theorem 4.1.A.** The area of the parallelogram determined by  $\vec{b}$  and  $\vec{c}$  in  $\mathbb{R}^3$  is  $\|\vec{b} \times \vec{c}\|$ .

**Proof (continued).** ...

$$\begin{aligned} A^2 &= (b_2c_3 - b_3c_2)^2 + (b_1c_3 - b_3c_1)^2 + (b_1c_2 - b_2c_1)^2 \\ &= \begin{vmatrix} b_2 & b_3 \\ c_2 & c_3 \end{vmatrix}^2 + \begin{vmatrix} b_1 & b_3 \\ c_1 & c_3 \end{vmatrix}^2 + \begin{vmatrix} b_1 & b_2 \\ c_1 & c_2 \end{vmatrix}^2 \\ &= \left\| \begin{vmatrix} b_2 & b_3 \\ c_2 & c_3 \end{vmatrix} \hat{i} - \begin{vmatrix} b_1 & b_3 \\ c_1 & c_3 \end{vmatrix} \hat{j} + \begin{vmatrix} b_1 & b_2 \\ c_1 & c_2 \end{vmatrix} \hat{k} \right\| = \|\vec{b} \times \vec{c}\|^2. \end{aligned}$$

Taking square roots we see that the claim is verified. □

## Theorem 4.1.B

**Theorem 4.1.B.** The volume of a box determined by vectors  $\vec{a}, \vec{b}, \vec{c} \in \mathbb{R}^3$  is  $V = |a_1(b_2c_3 - b_3c_2) - a_2(b_1c_3 - b_3c_1) + a_3(b_1c_2 - b_2c_1)| = |\vec{a} \cdot \vec{b} \times \vec{c}|$ .

**Proof.** Consider the box determined by  $\vec{a}, \vec{b}, \vec{c} \in \mathbb{R}^3$ :

## Theorem 4.1.B

**Theorem 4.1.B.** The volume of a box determined by vectors  $\vec{a}, \vec{b}, \vec{c} \in \mathbb{R}^3$  is  $V = |a_1(b_2c_3 - b_3c_2) - a_2(b_1c_3 - b_3c_1) + a_3(b_1c_2 - b_2c_1)| = |\vec{a} \cdot \vec{b} \times \vec{c}|$ .

**Proof.** Consider the box determined by  $\vec{a}, \vec{b}, \vec{c} \in \mathbb{R}^3$ :

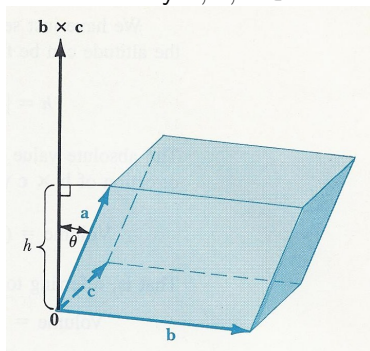

Figure 4.5, Page 244.

The volume of the box is the height times the area of the base.



## Theorem 4.1.B

**Theorem 4.1.B.** The volume of a box determined by vectors  $\vec{a}, \vec{b}, \vec{c} \in \mathbb{R}^3$  is  $V = |a_1(b_2c_3 - b_3c_2) - a_2(b_1c_3 - b_3c_1) + a_3(b_1c_2 - b_2c_1)| = |\vec{a} \cdot \vec{b} \times \vec{c}|$ .

**Proof.** Consider the box determined by  $\vec{a}, \vec{b}, \vec{c} \in \mathbb{R}^3$ :

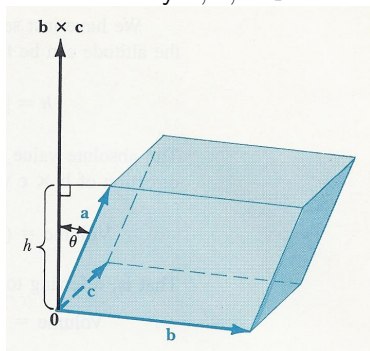

Figure 4.5, Page 244.

The volume of the box is the height times the area of the base.

## Theorem 4.1.B (continued)

**Theorem 4.1.B.** The volume of a box determined by vectors  $\vec{a}, \vec{b}, \vec{c} \in \mathbb{R}^3$  is  $V = |a_1(b_2c_3 - b_3c_2) - a_2(b_1c_3 - b_3c_1) + a_3(b_1c_2 - b_2c_1)| = |\vec{a} \cdot \vec{b} \times \vec{c}|$ .

**Proof (continued).** The area of the base is  $\|\vec{b} \times \vec{c}\|$  by Theorem 4.1.A. Now the height is

$$h = \|\vec{a}\| |\cos \theta| = \frac{\|\vec{b} \times \vec{c}\| \|\vec{a}\| |\cos \theta|}{\|\vec{b} \times \vec{c}\|} = \frac{|(\vec{b} \times \vec{c}) \cdot \vec{a}|}{\|\vec{b} \times \vec{c}\|}.$$

(Notice that if  $\vec{b} \times \vec{c}$  is in the opposite direction as given in the illustration above, then  $\theta$  would be greater than  $\pi/2$  and  $\cos \theta$  would be negative. Therefore the absolute value is necessary.)

## Theorem 4.1.B (continued)

**Theorem 4.1.B.** The volume of a box determined by vectors  $\vec{a}, \vec{b}, \vec{c} \in \mathbb{R}^3$  is  $V = |a_1(b_2c_3 - b_3c_2) - a_2(b_1c_3 - b_3c_1) + a_3(b_1c_2 - b_2c_1)| = |\vec{a} \cdot \vec{b} \times \vec{c}|$ .

**Proof (continued).** The area of the base is  $\|\vec{b} \times \vec{c}\|$  by Theorem 4.1.A. Now the height is

$$h = \|\vec{a}\| |\cos \theta| = \frac{\|\vec{b} \times \vec{c}\| \|\vec{a}\| |\cos \theta|}{\|\vec{b} \times \vec{c}\|} = \frac{|(\vec{b} \times \vec{c}) \cdot \vec{a}|}{\|\vec{b} \times \vec{c}\|}.$$

(Notice that if  $\vec{b} \times \vec{c}$  is in the opposite direction as given in the illustration above, then  $\theta$  would be greater than  $\pi/2$  and  $\cos \theta$  would be negative. Therefore the absolute value is necessary.) Therefore

$$V = (\text{Area of base})(\text{height}) = \|\vec{b} \times \vec{c}\| \frac{|(\vec{b} \times \vec{c}) \cdot \vec{a}|}{\|\vec{b} \times \vec{c}\|} = |(\vec{b} \times \vec{c}) \cdot \vec{a}|.$$



## Theorem 4.1.B (continued)

**Theorem 4.1.B.** The volume of a box determined by vectors  $\vec{a}, \vec{b}, \vec{c} \in \mathbb{R}^3$  is  $V = |a_1(b_2c_3 - b_3c_2) - a_2(b_1c_3 - b_3c_1) + a_3(b_1c_2 - b_2c_1)| = |\vec{a} \cdot \vec{b} \times \vec{c}|$ .

**Proof (continued).** The area of the base is  $\|\vec{b} \times \vec{c}\|$  by Theorem 4.1.A. Now the height is

$$h = \|\vec{a}\| |\cos \theta| = \frac{\|\vec{b} \times \vec{c}\| \|\vec{a}\| |\cos \theta|}{\|\vec{b} \times \vec{c}\|} = \frac{|(\vec{b} \times \vec{c}) \cdot \vec{a}|}{\|\vec{b} \times \vec{c}\|}.$$

(Notice that if  $\vec{b} \times \vec{c}$  is in the opposite direction as given in the illustration above, then  $\theta$  would be greater than  $\pi/2$  and  $\cos \theta$  would be negative. Therefore the absolute value is necessary.) Therefore

$$V = (\text{Area of base})(\text{height}) = \|\vec{b} \times \vec{c}\| \frac{|(\vec{b} \times \vec{c}) \cdot \vec{a}|}{\|\vec{b} \times \vec{c}\|} = |(\vec{b} \times \vec{c}) \cdot \vec{a}|.$$



# Page 249 Number 38

**Page 249 Number 38.** Find the volume of the box having the vectors (in standard position)  $2\hat{i} + \hat{j} - 4\hat{k}$ ,  $3\hat{i} - \hat{j} + 2\hat{k}$ ,  $\hat{i} + 3\hat{j} - 8\hat{k}$  as adjacent edges.

**Solution.** Let  $\vec{a} = [a_1, a_2, a_3] = 2\hat{i} + \hat{j} - 4\hat{k} = [2, 1, -4]$ ,

$\vec{b} = [b_1, b_2, b_3] = 3\hat{i} - \hat{j} + 2\hat{k} = [3, -1, 2]$ , and

$\vec{c} = [c_1, c_2, c_3] = \hat{i} + 3\hat{j} - 8\hat{k} = [1, 3, -8]$ . Then by the previous Note, the volume of the box is  $|\det(A)|$  where

$$A = \begin{bmatrix} a_1 & a_2 & a_3 \\ b_1 & b_2 & b_3 \\ c_1 & c_2 & c_3 \end{bmatrix} = \begin{bmatrix} 2 & 1 & -4 \\ 3 & -1 & 2 \\ 1 & 3 & -8 \end{bmatrix}.$$

## Page 249 Number 38

**Page 249 Number 38.** Find the volume of the box having the vectors (in standard position)  $2\hat{i} + \hat{j} - 4\hat{k}$ ,  $3\hat{i} - \hat{j} + 2\hat{k}$ ,  $\hat{i} + 3\hat{j} - 8\hat{k}$  as adjacent edges.

**Solution.** Let  $\vec{a} = [a_1, a_2, a_3] = 2\hat{i} + \hat{j} - 4\hat{k} = [2, 1, -4]$ ,

$\vec{b} = [b_1, b_2, b_3] = 3\hat{i} - \hat{j} + 2\hat{k} = [3, -1, 2]$ , and

$\vec{c} = [c_1, c_2, c_3] = \hat{i} + 3\hat{j} - 8\hat{k} = [1, 3, -8]$ . Then by the previous Note, the volume of the box is  $|\det(A)|$  where

$$A = \begin{bmatrix} a_1 & a_2 & a_3 \\ b_1 & b_2 & b_3 \\ c_1 & c_2 & c_3 \end{bmatrix} = \begin{bmatrix} 2 & 1 & -4 \\ 3 & -1 & 2 \\ 1 & 3 & -8 \end{bmatrix}. \text{ So the volume is}$$

$$\left| \begin{vmatrix} 2 & 1 & -4 \\ 3 & -1 & 2 \\ 1 & 3 & -8 \end{vmatrix} \right| = \left| (2) \begin{vmatrix} -1 & 2 \\ 3 & -8 \end{vmatrix} - (1) \begin{vmatrix} 3 & 2 \\ 1 & -8 \end{vmatrix} + (-4) \begin{vmatrix} 3 & -1 \\ 1 & 3 \end{vmatrix} \right|$$

## Page 249 Number 38

**Page 249 Number 38.** Find the volume of the box having the vectors (in standard position)  $2\hat{i} + \hat{j} - 4\hat{k}$ ,  $3\hat{i} - \hat{j} + 2\hat{k}$ ,  $\hat{i} + 3\hat{j} - 8\hat{k}$  as adjacent edges.

**Solution.** Let  $\vec{a} = [a_1, a_2, a_3] = 2\hat{i} + \hat{j} - 4\hat{k} = [2, 1, -4]$ ,

$\vec{b} = [b_1, b_2, b_3] = 3\hat{i} - \hat{j} + 2\hat{k} = [3, -1, 2]$ , and

$\vec{c} = [c_1, c_2, c_3] = \hat{i} + 3\hat{j} - 8\hat{k} = [1, 3, -8]$ . Then by the previous Note, the volume of the box is  $|\det(A)|$  where

$$A = \begin{bmatrix} a_1 & a_2 & a_3 \\ b_1 & b_2 & b_3 \\ c_1 & c_2 & c_3 \end{bmatrix} = \begin{bmatrix} 2 & 1 & -4 \\ 3 & -1 & 2 \\ 1 & 3 & -8 \end{bmatrix}. \text{ So the volume is}$$

$$\left| \begin{vmatrix} 2 & 1 & -4 \\ 3 & -1 & 2 \\ 1 & 3 & -8 \end{vmatrix} \right| = \left| (2) \begin{vmatrix} -1 & 2 \\ 3 & -8 \end{vmatrix} - (1) \begin{vmatrix} 3 & 2 \\ 1 & -8 \end{vmatrix} + (-4) \begin{vmatrix} 3 & -1 \\ 1 & 3 \end{vmatrix} \right|$$

$$= |2((-1)(-8) - (2)(3)) - ((3)(-8) - (2)(1)) - 4((3)(3) - (-1)(1))|$$

$$= |2(2) - (-26) - 4(10)| = \boxed{10}. \quad \square$$

## Page 249 Number 38

**Page 249 Number 38.** Find the volume of the box having the vectors (in standard position)  $2\hat{i} + \hat{j} - 4\hat{k}$ ,  $3\hat{i} - \hat{j} + 2\hat{k}$ ,  $\hat{i} + 3\hat{j} - 8\hat{k}$  as adjacent edges.

**Solution.** Let  $\vec{a} = [a_1, a_2, a_3] = 2\hat{i} + \hat{j} - 4\hat{k} = [2, 1, -4]$ ,

$\vec{b} = [b_1, b_2, b_3] = 3\hat{i} - \hat{j} + 2\hat{k} = [3, -1, 2]$ , and

$\vec{c} = [c_1, c_2, c_3] = \hat{i} + 3\hat{j} - 8\hat{k} = [1, 3, -8]$ . Then by the previous Note, the volume of the box is  $|\det(A)|$  where

$$A = \begin{bmatrix} a_1 & a_2 & a_3 \\ b_1 & b_2 & b_3 \\ c_1 & c_2 & c_3 \end{bmatrix} = \begin{bmatrix} 2 & 1 & -4 \\ 3 & -1 & 2 \\ 1 & 3 & -8 \end{bmatrix}. \text{ So the volume is}$$

$$\left| \begin{vmatrix} 2 & 1 & -4 \\ 3 & -1 & 2 \\ 1 & 3 & -8 \end{vmatrix} \right| = \left| (2) \begin{vmatrix} -1 & 2 \\ 3 & -8 \end{vmatrix} - (1) \begin{vmatrix} 3 & 2 \\ 1 & -8 \end{vmatrix} + (-4) \begin{vmatrix} 3 & -1 \\ 1 & 3 \end{vmatrix} \right|$$

$$= |2((-1)(-8) - (2)(3)) - ((3)(-8) - (2)(1)) - 4((3)(3) - (-1)(1))|$$

$$= |2(2) - (-26) - 4(10)| = \boxed{10}. \quad \square$$



# Page 249 Number 50

**Page 249 Number 50.** Use a determinant to ascertain whether the points  $(0, 0, 0)$ ,  $(2, 1, 1)$ ,  $(3, -2, 1)$ ,  $(-1, 2, 3)$  lie in a plane in  $\mathbb{R}^3$ .

**Solution.** We introduce three vectors determining a box. If the volume of the box is 0 then the points are in the same plane and if the volume is positive then the points are not coplanar.

## Page 249 Number 50

**Page 249 Number 50.** Use a determinant to ascertain whether the points  $(0, 0, 0)$ ,  $(2, 1, 1)$ ,  $(3, -2, 1)$ ,  $(-1, 2, 3)$  lie in a plane in  $\mathbb{R}^3$ .

**Solution.** We introduce three vectors determining a box. If the volume of the box is 0 then the points are in the same plane and if the volume is positive then the points are not coplanar. So we take vectors from  $(0, 0, 0)$  to the other three points:

$$\vec{a} = [a_1, a_2, a_3] = [(2) - (0), (1) - (0), (1) - (0)] = [2, 1, 1],$$

$$\vec{b} = [b_1, b_2, b_3] = [(3) - (0), (-2) - (0), (1) - (0)] = [3, -2, 1],$$

$$\vec{c} = [c_1, c_2, c_3] = [(-1) - (0), (2) - (0), (3) - (0)] = [-1, 2, 3].$$

## Page 249 Number 50

**Page 249 Number 50.** Use a determinant to ascertain whether the points  $(0, 0, 0)$ ,  $(2, 1, 1)$ ,  $(3, -2, 1)$ ,  $(-1, 2, 3)$  lie in a plane in  $\mathbb{R}^3$ .

**Solution.** We introduce three vectors determining a box. If the volume of the box is 0 then the points are in the same plane and if the volume is positive then the points are not coplanar. So we take vectors from  $(0, 0, 0)$  to the other three points:

$$\vec{a} = [a_1, a_2, a_3] = [(2) - (0), (1) - (0), (1) - (0)] = [2, 1, 1],$$

$$\vec{b} = [b_1, b_2, b_3] = [(3) - (0), (-2) - (0), (1) - (0)] = [3, -2, 1],$$

$$\vec{c} = [c_1, c_2, c_3] = [(-1) - (0), (2) - (0), (3) - (0)] = [-1, 2, 3].$$
 Then with

$$A = \begin{bmatrix} a_1 & a_2 & a_3 \\ b_1 & b_2 & b_3 \\ c_1 & c_2 & c_3 \end{bmatrix} = \begin{bmatrix} 2 & 1 & 1 \\ 3 & -2 & 1 \\ -1 & 2 & 3 \end{bmatrix},$$
 the volume of the box is

$$|\det(A)|:$$

## Page 249 Number 50

**Page 249 Number 50.** Use a determinant to ascertain whether the points  $(0, 0, 0)$ ,  $(2, 1, 1)$ ,  $(3, -2, 1)$ ,  $(-1, 2, 3)$  lie in a plane in  $\mathbb{R}^3$ .

**Solution.** We introduce three vectors determining a box. If the volume of the box is 0 then the points are in the same plane and if the volume is positive then the points are not coplanar. So we take vectors from  $(0, 0, 0)$  to the other three points:

$$\vec{a} = [a_1, a_2, a_3] = [(2) - (0), (1) - (0), (1) - (0)] = [2, 1, 1],$$

$$\vec{b} = [b_1, b_2, b_3] = [(3) - (0), (-2) - (0), (1) - (0)] = [3, -2, 1],$$

$$\vec{c} = [c_1, c_2, c_3] = [(-1) - (0), (2) - (0), (3) - (0)] = [-1, 2, 3]. \text{ Then with}$$

$$A = \begin{bmatrix} a_1 & a_2 & a_3 \\ b_1 & b_2 & b_3 \\ c_1 & c_2 & c_3 \end{bmatrix} = \begin{bmatrix} 2 & 1 & 1 \\ 3 & -2 & 1 \\ -1 & 2 & 3 \end{bmatrix}, \text{ the volume of the box is}$$

$$|\det(A)|:$$

# Page 249 Number 50 (continued)

**Page 249 Number 50.** Use a determinant to ascertain whether the points  $(0, 0, 0)$ ,  $(2, 1, 1)$ ,  $(3, -2, 1)$ ,  $(-1, 2, 3)$  lie in a plane in  $\mathbb{R}^3$ .

**Solution (continued).** ... the volume of the box is  $|\det(A)|$ :

$$\begin{aligned} \left| \begin{vmatrix} 2 & 1 & 1 \\ 3 & -2 & 1 \\ -1 & 2 & 3 \end{vmatrix} \right| &= \left| (2) \begin{vmatrix} -2 & 1 \\ 2 & 3 \end{vmatrix} - (1) \begin{vmatrix} 3 & 1 \\ -1 & 3 \end{vmatrix} + (1) \begin{vmatrix} 3 & -2 \\ -1 & 2 \end{vmatrix} \right| \\ &= |2((-2)(3) - (1)(2)) - ((3)(3) - (1)(-1)) + ((3)(2) - (-2)(-1))| \\ &= |2(-8) - (10) + (4)| = 22. \end{aligned}$$

## Page 249 Number 50 (continued)

**Page 249 Number 50.** Use a determinant to ascertain whether the points  $(0, 0, 0)$ ,  $(2, 1, 1)$ ,  $(3, -2, 1)$ ,  $(-1, 2, 3)$  lie in a plane in  $\mathbb{R}^3$ .

**Solution (continued).** ... the volume of the box is  $|\det(A)|$ :

$$\begin{aligned} \left| \begin{vmatrix} 2 & 1 & 1 \\ 3 & -2 & 1 \\ -1 & 2 & 3 \end{vmatrix} \right| &= \left| (2) \begin{vmatrix} -2 & 1 \\ 2 & 3 \end{vmatrix} - (1) \begin{vmatrix} 3 & 1 \\ -1 & 3 \end{vmatrix} + (1) \begin{vmatrix} 3 & -2 \\ -1 & 2 \end{vmatrix} \right| \\ &= |2((-2)(3) - (1)(2)) - ((3)(3) - (1)(-1)) + ((3)(2) - (-2)(-1))| \\ &= |2(-8) - (10) + (4)| = 22. \end{aligned}$$

Since the volume is not 0, then the points do not lie in a plane in  $\mathbb{R}^3$ .  $\square$

## Page 249 Number 50 (continued)

**Page 249 Number 50.** Use a determinant to ascertain whether the points  $(0, 0, 0)$ ,  $(2, 1, 1)$ ,  $(3, -2, 1)$ ,  $(-1, 2, 3)$  lie in a plane in  $\mathbb{R}^3$ .

**Solution (continued).** ... the volume of the box is  $|\det(A)|$ :

$$\begin{aligned} \left| \begin{vmatrix} 2 & 1 & 1 \\ 3 & -2 & 1 \\ -1 & 2 & 3 \end{vmatrix} \right| &= \left| (2) \begin{vmatrix} -2 & 1 \\ 2 & 3 \end{vmatrix} - (1) \begin{vmatrix} 3 & 1 \\ -1 & 3 \end{vmatrix} + (1) \begin{vmatrix} 3 & -2 \\ -1 & 2 \end{vmatrix} \right| \\ &= |2((-2)(3) - (1)(2)) - ((3)(3) - (1)(-1)) + ((3)(2) - (-2)(-1))| \\ &= |2(-8) - (10) + (4)| = 22. \end{aligned}$$

Since the volume is not 0, then the points do not lie in a plane in  $\mathbb{R}^3$ .  $\square$

## Theorem 4.1

**Theorem 4.1. Properties of Cross Product.**Let  $\vec{a}, \vec{b}, \vec{c} \in \mathbb{R}^3$ .**(1)** Anticommutivity:  $\vec{b} \times \vec{c} = -\vec{c} \times \vec{b}$ **(3)** Distributive Properties:  $\vec{a} \times (\vec{b} + \vec{c}) = (\vec{a} \times \vec{b}) + (\vec{a} \times \vec{c})$ **Proof. (1)** Page 247 Example 8. We have

$$\begin{aligned}
 \vec{b} \times \vec{c} &= \begin{vmatrix} b_2 & b_3 \\ c_2 & c_3 \end{vmatrix} \hat{i} - \begin{vmatrix} b_1 & b_3 \\ c_1 & c_3 \end{vmatrix} \hat{j} + \begin{vmatrix} b_1 & b_2 \\ c_1 & c_2 \end{vmatrix} \hat{k} \\
 &= (b_2c_3 - b_3c_2)\hat{i} - (b_1c_3 - b_3c_1)\hat{j} + (b_1c_2 - b_2c_1)\hat{k} \\
 &= -\left( (b_3c_2 - b_2c_3)\hat{i} - (b_3c_1 - b_1c_3)\hat{j} + (b_2c_1 - b_1c_2)\hat{k} \right)
 \end{aligned}$$



## Theorem 4.1

**Theorem 4.1. Properties of Cross Product.**Let  $\vec{a}, \vec{b}, \vec{c} \in \mathbb{R}^3$ .**(1)** Anticommutivity:  $\vec{b} \times \vec{c} = -\vec{c} \times \vec{b}$ **(3)** Distributive Properties:  $\vec{a} \times (\vec{b} + \vec{c}) = (\vec{a} \times \vec{b}) + (\vec{a} \times \vec{c})$ **Proof. (1)** Page 247 Example 8. We have

$$\begin{aligned}
 \vec{b} \times \vec{c} &= \begin{vmatrix} b_2 & b_3 \\ c_2 & c_3 \end{vmatrix} \hat{i} - \begin{vmatrix} b_1 & b_3 \\ c_1 & c_3 \end{vmatrix} \hat{j} + \begin{vmatrix} b_1 & b_2 \\ c_1 & c_2 \end{vmatrix} \hat{k} \\
 &= (b_2c_3 - b_3c_2)\hat{i} - (b_1c_3 - b_3c_1)\hat{j} + (b_1c_2 - b_2c_1)\hat{k} \\
 &= -\left( (b_3c_2 - b_2c_3)\hat{i} - (b_3c_1 - b_1c_3)\hat{j} + (b_2c_1 - b_1c_2)\hat{k} \right) \\
 &= -\left( \begin{vmatrix} c_2 & c_3 \\ b_2 & b_3 \end{vmatrix} \hat{i} - \begin{vmatrix} c_1 & c_3 \\ b_1 & b_3 \end{vmatrix} \hat{j} + \begin{vmatrix} c_1 & c_2 \\ b_1 & b_2 \end{vmatrix} \hat{k} \right) \\
 &= -\vec{c} \times \vec{b}
 \end{aligned}$$

## Theorem 4.1

**Theorem 4.1. Properties of Cross Product.**Let  $\vec{a}, \vec{b}, \vec{c} \in \mathbb{R}^3$ .**(1)** Anticommutivity:  $\vec{b} \times \vec{c} = -\vec{c} \times \vec{b}$ **(3)** Distributive Properties:  $\vec{a} \times (\vec{b} + \vec{c}) = (\vec{a} \times \vec{b}) + (\vec{a} \times \vec{c})$ **Proof. (1)** Page 247 Example 8. We have

$$\begin{aligned}
 \vec{b} \times \vec{c} &= \begin{vmatrix} b_2 & b_3 \\ c_2 & c_3 \end{vmatrix} \hat{i} - \begin{vmatrix} b_1 & b_3 \\ c_1 & c_3 \end{vmatrix} \hat{j} + \begin{vmatrix} b_1 & b_2 \\ c_1 & c_2 \end{vmatrix} \hat{k} \\
 &= (b_2 c_3 - b_3 c_2) \hat{i} - (b_1 c_3 - b_3 c_1) \hat{j} + (b_1 c_2 - b_2 c_1) \hat{k} \\
 &= - \left( (b_3 c_2 - b_2 c_3) \hat{i} - (b_3 c_1 - b_1 c_3) \hat{j} + (b_2 c_1 - b_1 c_2) \hat{k} \right) \\
 &= - \left( \begin{vmatrix} c_2 & c_3 \\ b_2 & b_3 \end{vmatrix} \hat{i} - \begin{vmatrix} c_1 & c_3 \\ b_1 & b_3 \end{vmatrix} \hat{j} + \begin{vmatrix} c_1 & c_2 \\ b_1 & b_2 \end{vmatrix} \hat{k} \right) \\
 &= -\vec{c} \times \vec{b}
 \end{aligned}$$

## Theorem 4.1 (continued 1)

**Theorem 4.1. Properties of Cross Product.**Let  $\vec{a}, \vec{b}, \vec{c} \in \mathbb{R}^3$ .**(3) Distributive Properties:**  $\vec{a} \times (\vec{b} + \vec{c}) = (\vec{a} \times \vec{b}) + (\vec{a} \times \vec{c})$ **Proof (continued).** **(3)** Page 249 Number 58. We have

$$\vec{a} \times (\vec{b} + \vec{c}) = [a_1, a_2, a_3] \times ([b_1, b_2, b_3] + [c_1, c_2, c_3])$$

$$= [a_1, a_2, a_3] \times [b_1 + c_1, b_2 + c_2, b_3 + c_3] = \begin{vmatrix} \hat{i} & \hat{j} & \hat{k} \\ a_1 & a_2 & a_3 \\ b_1 + c_1 & b_2 + c_2 & b_3 + c_3 \end{vmatrix}$$

$$= \begin{vmatrix} a_2 & a_3 \\ b_2 + c_2 & b_3 + c_3 \end{vmatrix} \hat{i} - \begin{vmatrix} a_1 & a_3 \\ b_1 + c_1 & b_3 + c_3 \end{vmatrix} \hat{j} + \begin{vmatrix} a_1 & a_2 \\ b_1 + c_1 & b_2 + c_2 \end{vmatrix} \hat{k}$$

## Theorem 4.1 (continued 1)

**Theorem 4.1. Properties of Cross Product.**Let  $\vec{a}, \vec{b}, \vec{c} \in \mathbb{R}^3$ .**(3) Distributive Properties:**  $\vec{a} \times (\vec{b} + \vec{c}) = (\vec{a} \times \vec{b}) + (\vec{a} \times \vec{c})$ **Proof (continued).** **(3)** Page 249 Number 58. We have

$$\vec{a} \times (\vec{b} + \vec{c}) = [a_1, a_2, a_3] \times ([b_1, b_2, b_3] + [c_1, c_2, c_3])$$

$$= [a_1, a_2, a_3] \times [b_1 + c_1, b_2 + c_2, b_3 + c_3] = \begin{vmatrix} \hat{i} & \hat{j} & \hat{k} \\ a_1 & a_2 & a_3 \\ b_1 + c_1 & b_2 + c_2 & b_3 + c_3 \end{vmatrix}$$

$$= \begin{vmatrix} a_2 & a_3 \\ b_2 + c_2 & b_3 + c_3 \end{vmatrix} \hat{i} - \begin{vmatrix} a_1 & a_3 \\ b_1 + c_1 & b_3 + c_3 \end{vmatrix} \hat{j} + \begin{vmatrix} a_1 & a_2 \\ b_1 + c_1 & b_2 + c_2 \end{vmatrix} \hat{k}$$

## Theorem 4.1 (continued 2)

**Proof (continued).** ...

$$\begin{aligned}
 &= ((a_2)(b_3 + c_3) - (a_3)(b_2 + c_2))\hat{i} - ((a_1)(b_3 + c_3) - (a_3)(b_1 + c_1))\hat{j} \\
 &\quad + ((a_1)(b_2 + c_2) - (a_2)(b_1 + c_1))\hat{k} \\
 &= (a_2b_3 + a_2c_3 - a_3b_2 - a_3c_2)\hat{i} - (a_1b_3 + a_1c_3 - a_3b_1 - a_3c_1)\hat{j} \\
 &\quad + (a_1b_2 + a_1c_2 - a_2b_1 - a_2c_1)\hat{k} \\
 &= ((a_2b_3 - a_3b_2) + (a_2c_3 - a_3c_2))\hat{i} - ((a_1b_3 - a_3b_1) + (a_1c_3 - a_3c_1))\hat{j} \\
 &\quad + ((a_1b_2 - a_2b_1) + (a_1c_2 - a_2c_1))\hat{k} \\
 &= \left( \begin{pmatrix} a_2 & a_3 \\ b_2 & b_3 \end{pmatrix} + \begin{pmatrix} a_2 & a_3 \\ c_2 & c_3 \end{pmatrix} \right) \hat{i} - \left( \begin{pmatrix} a_1 & a_3 \\ b_1 & b_3 \end{pmatrix} + \begin{pmatrix} a_1 & a_3 \\ c_1 & c_3 \end{pmatrix} \right) \hat{j} \\
 &\quad + \left( \begin{pmatrix} a_1 & a_2 \\ b_1 & b_2 \end{pmatrix} + \begin{pmatrix} a_1 & a_2 \\ c_1 & c_2 \end{pmatrix} \right) \hat{k}
 \end{aligned}$$

## Theorem 4.1 (continued 2)

**Proof (continued).** ...

$$\begin{aligned}
 &= ((a_2)(b_3 + c_3) - (a_3)(b_2 + c_2))\hat{i} - ((a_1)(b_3 + c_3) - (a_3)(b_1 + c_1))\hat{j} \\
 &\quad + ((a_1)(b_2 + c_2) - (a_2)(b_1 + c_1))\hat{k} \\
 &= (a_2b_3 + a_2c_3 - a_3b_2 - a_3c_2)\hat{i} - (a_1b_3 + a_1c_3 - a_3b_1 - a_3c_1)\hat{j} \\
 &\quad + (a_1b_2 + a_1c_2 - a_2b_1 - a_2c_1)\hat{k} \\
 &= ((a_2b_3 - a_3b_2) + (a_2c_3 - a_3c_2))\hat{i} - ((a_1b_3 - a_3b_1) + (a_1c_3 - a_3c_1))\hat{j} \\
 &\quad + ((a_1b_2 - a_2b_1) + (a_1c_2 - a_2c_1))\hat{k} \\
 &= \left( \left( \begin{array}{cc|c} a_2 & a_3 & \\ b_2 & b_3 & \end{array} \right) + \left( \begin{array}{cc|c} a_2 & a_3 & \\ c_2 & c_3 & \end{array} \right) \right) \hat{i} - \left( \left( \begin{array}{cc|c} a_1 & a_3 & \\ b_1 & b_3 & \end{array} \right) + \left( \begin{array}{cc|c} a_1 & a_3 & \\ c_1 & c_3 & \end{array} \right) \right) \hat{j} \\
 &\quad + \left( \left( \begin{array}{cc|c} a_1 & a_2 & \\ b_1 & b_2 & \end{array} \right) + \left( \begin{array}{cc|c} a_1 & a_2 & \\ c_1 & c_2 & \end{array} \right) \right) \hat{k}
 \end{aligned}$$

## Theorem 4.1 (continued 3)

**Proof (continued).** ...

$$\begin{aligned}
 &= \begin{vmatrix} a_2 & a_3 \\ b_2 & b_3 \end{vmatrix} \hat{i} + \begin{vmatrix} a_2 & a_3 \\ c_2 & c_3 \end{vmatrix} \hat{i} - \begin{vmatrix} a_1 & a_3 \\ b_1 & b_3 \end{vmatrix} \hat{j} - \begin{vmatrix} a_1 & a_3 \\ c_1 & c_3 \end{vmatrix} \hat{j} \\
 &\quad + \begin{vmatrix} a_1 & a_2 \\ b_1 & b_2 \end{vmatrix} \hat{k} + \begin{vmatrix} a_1 & a_2 \\ c_1 & c_2 \end{vmatrix} \hat{k} \\
 &= \left( \begin{vmatrix} a_2 & a_3 \\ b_2 & b_3 \end{vmatrix} \hat{i} - \begin{vmatrix} a_1 & a_3 \\ b_1 & b_3 \end{vmatrix} \hat{j} + \begin{vmatrix} a_1 & a_2 \\ b_1 & b_2 \end{vmatrix} \hat{k} \right) \\
 &\quad + \left( \begin{vmatrix} a_2 & a_3 \\ c_2 & c_3 \end{vmatrix} \hat{i} - \begin{vmatrix} a_1 & a_3 \\ c_1 & c_3 \end{vmatrix} \hat{j} + \begin{vmatrix} a_1 & a_2 \\ c_1 & c_2 \end{vmatrix} \hat{k} \right) \\
 &= (\vec{a} \times \vec{b}) + (\vec{a} \times \vec{c}).
 \end{aligned}$$



## Theorem 4.1 (continued 3)

Proof (continued). ...

$$\begin{aligned}
&= \begin{vmatrix} a_2 & a_3 \\ b_2 & b_3 \end{vmatrix} \hat{i} + \begin{vmatrix} a_2 & a_3 \\ c_2 & c_3 \end{vmatrix} \hat{i} - \begin{vmatrix} a_1 & a_3 \\ b_1 & b_3 \end{vmatrix} \hat{j} - \begin{vmatrix} a_1 & a_3 \\ c_1 & c_3 \end{vmatrix} \hat{j} \\
&\quad + \begin{vmatrix} a_1 & a_2 \\ b_1 & b_2 \end{vmatrix} \hat{k} + \begin{vmatrix} a_1 & a_2 \\ c_1 & c_2 \end{vmatrix} \hat{k} \\
&= \left( \begin{vmatrix} a_2 & a_3 \\ b_2 & b_3 \end{vmatrix} \hat{i} - \begin{vmatrix} a_1 & a_3 \\ b_1 & b_3 \end{vmatrix} \hat{j} + \begin{vmatrix} a_1 & a_2 \\ b_1 & b_2 \end{vmatrix} \hat{k} \right) \\
&\quad + \left( \begin{vmatrix} a_2 & a_3 \\ c_2 & c_3 \end{vmatrix} \hat{i} - \begin{vmatrix} a_1 & a_3 \\ c_1 & c_3 \end{vmatrix} \hat{j} + \begin{vmatrix} a_1 & a_2 \\ c_1 & c_2 \end{vmatrix} \hat{k} \right) \\
&= (\vec{a} \times \vec{b}) + (\vec{a} \times \vec{c}).
\end{aligned}$$





## Page 249 Number 56

**Page 249 Number 56.** Let  $\vec{a}, \vec{b}, \vec{c}$  be vectors in  $\mathbb{R}^3$ . Simplify the expression  $\vec{a} \times (\vec{b} \times \vec{c}) + \vec{b} \times (\vec{c} \times \vec{a}) + \vec{c} \times (\vec{a} \times \vec{b})$ .

**Solution.** By Theorem 4.1(7), "Properties of Cross Products,"

$$\vec{a} \times (\vec{b} \times \vec{c}) = (\vec{a} \cdot \vec{c})\vec{b} - (\vec{a} \cdot \vec{b})\vec{c}, \text{ and so } \vec{b} \times (\vec{c} \times \vec{a}) = (\vec{b} \cdot \vec{a})\vec{c} - (\vec{b} \cdot \vec{c})\vec{a},$$
$$\vec{c} \times (\vec{a} \times \vec{b}) = (\vec{c} \cdot \vec{b})\vec{a} - (\vec{c} \cdot \vec{a})\vec{b}.$$

## Page 249 Number 56

**Page 249 Number 56.** Let  $\vec{a}, \vec{b}, \vec{c}$  be vectors in  $\mathbb{R}^3$ . Simplify the expression  $\vec{a} \times (\vec{b} \times \vec{c}) + \vec{b} \times (\vec{c} \times \vec{a}) + \vec{c} \times (\vec{a} \times \vec{b})$ .

**Solution.** By Theorem 4.1(7), “Properties of Cross Products,”

$\vec{a} \times (\vec{b} \times \vec{c}) = (\vec{a} \cdot \vec{c})\vec{b} - (\vec{a} \cdot \vec{b})\vec{c}$ , and so  $\vec{b} \times (\vec{c} \times \vec{a}) = (\vec{b} \cdot \vec{a})\vec{c} - (\vec{b} \cdot \vec{c})\vec{a}$ ,  
 $\vec{c} \times (\vec{a} \times \vec{b}) = (\vec{c} \cdot \vec{b})\vec{a} - (\vec{c} \cdot \vec{a})\vec{b}$ . Hence

$$\begin{aligned} & \vec{a} \times (\vec{b} \times \vec{c}) + \vec{b} \times (\vec{c} \times \vec{a}) + \vec{c} \times (\vec{a} \times \vec{b}) \\ &= \left( (\vec{a} \cdot \vec{c})\vec{b} - (\vec{a} \cdot \vec{b})\vec{c} \right) + \left( (\vec{b} \cdot \vec{a})\vec{c} - (\vec{b} \cdot \vec{c})\vec{a} \right) + \left( (\vec{c} \cdot \vec{b})\vec{a} - (\vec{c} \cdot \vec{a})\vec{b} \right) \\ &= (\vec{a} \cdot \vec{c} - \vec{c} \cdot \vec{a})\vec{b} + (\vec{b} \cdot \vec{a} - \vec{a} \cdot \vec{b})\vec{c} + (\vec{c} \cdot \vec{b} - \vec{b} \cdot \vec{c})\vec{a} \\ &= 0\vec{b} + 0\vec{c} + 0\vec{a} \text{ since dot product is commutative by} \\ & \quad \text{Theorem 1.3(D1), “Properties of Dot Products”} \\ &= \boxed{\vec{0}}. \end{aligned}$$

□

## Page 249 Number 56

**Page 249 Number 56.** Let  $\vec{a}, \vec{b}, \vec{c}$  be vectors in  $\mathbb{R}^3$ . Simplify the expression  $\vec{a} \times (\vec{b} \times \vec{c}) + \vec{b} \times (\vec{c} \times \vec{a}) + \vec{c} \times (\vec{a} \times \vec{b})$ .

**Solution.** By Theorem 4.1(7), “Properties of Cross Products,”

$\vec{a} \times (\vec{b} \times \vec{c}) = (\vec{a} \cdot \vec{c})\vec{b} - (\vec{a} \cdot \vec{b})\vec{c}$ , and so  $\vec{b} \times (\vec{c} \times \vec{a}) = (\vec{b} \cdot \vec{a})\vec{c} - (\vec{b} \cdot \vec{c})\vec{a}$ ,  
 $\vec{c} \times (\vec{a} \times \vec{b}) = (\vec{c} \cdot \vec{b})\vec{a} - (\vec{c} \cdot \vec{a})\vec{b}$ . Hence

$$\begin{aligned} & \vec{a} \times (\vec{b} \times \vec{c}) + \vec{b} \times (\vec{c} \times \vec{a}) + \vec{c} \times (\vec{a} \times \vec{b}) \\ &= \left( (\vec{a} \cdot \vec{c})\vec{b} - (\vec{a} \cdot \vec{b})\vec{c} \right) + \left( (\vec{b} \cdot \vec{a})\vec{c} - (\vec{b} \cdot \vec{c})\vec{a} \right) + \left( (\vec{c} \cdot \vec{b})\vec{a} - (\vec{c} \cdot \vec{a})\vec{b} \right) \\ &= (\vec{a} \cdot \vec{c} - \vec{c} \cdot \vec{a})\vec{b} + (\vec{b} \cdot \vec{a} - \vec{a} \cdot \vec{b})\vec{c} + (\vec{c} \cdot \vec{b} - \vec{b} \cdot \vec{c})\vec{a} \\ &= 0\vec{b} + 0\vec{c} + 0\vec{a} \text{ since dot product is commutative by} \\ & \quad \text{Theorem 1.3(D1), “Properties of Dot Products”} \\ &= \boxed{\vec{0}}. \end{aligned}$$

□