

Revisions

Rev	Description	Date	Appvd
A	Dimensions Changed (2014)	2014 Jun30	WKH
B	Thread Specif Corrected	2018Apr04	WKH

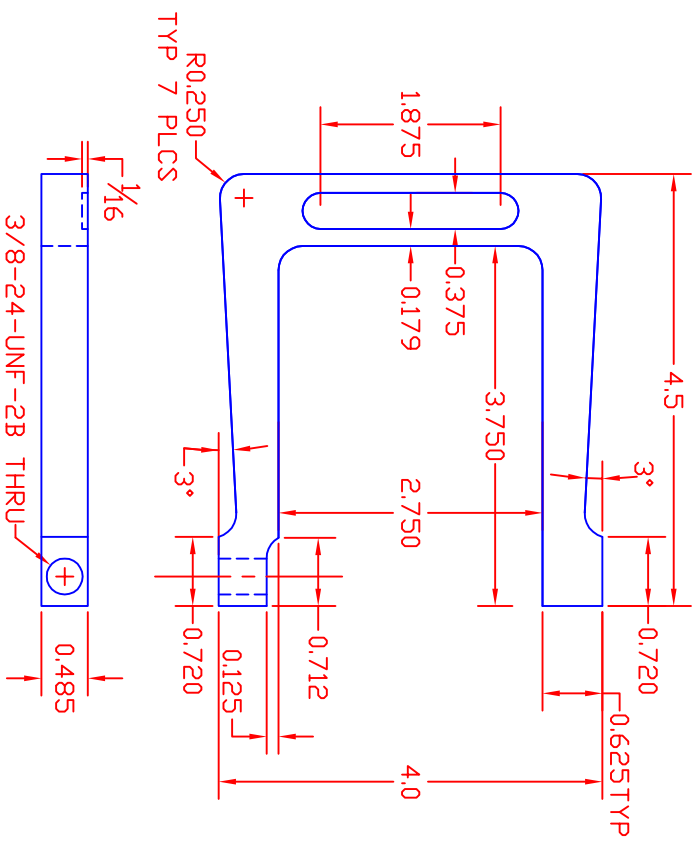

-145 U-Frame, LC - Shown
 -245 U-Frame, Brass - Same as
 -145 except as shown

Dash No	Description	Material	Specif.	Stock Size
-245	U-Frame, Brass	Brass	360 H02	4.5 x 4 x 1/2
-145	U-Frame, LC Steel	1018 LC Stl	AISI 1018	4.5 x 4 x 1/2

Tolerances

X± 0.1
 XX ± 0.03
 .XXX ± 0.005
 Fractional ±1/64
 Angular ±0.5

Unless Otherwise
 Noted

ETSU ENTC 2170 CADD

Dwg Name U-Clamp Assy
 Frame, U-Clamp, Details of

Size	Date	Dwg No.	Rev
A	2018Apr04	2170-013-51	B
Scale	NTS	Dwg by	J BOSWORTH BILLINGSBY